

SIEMENS

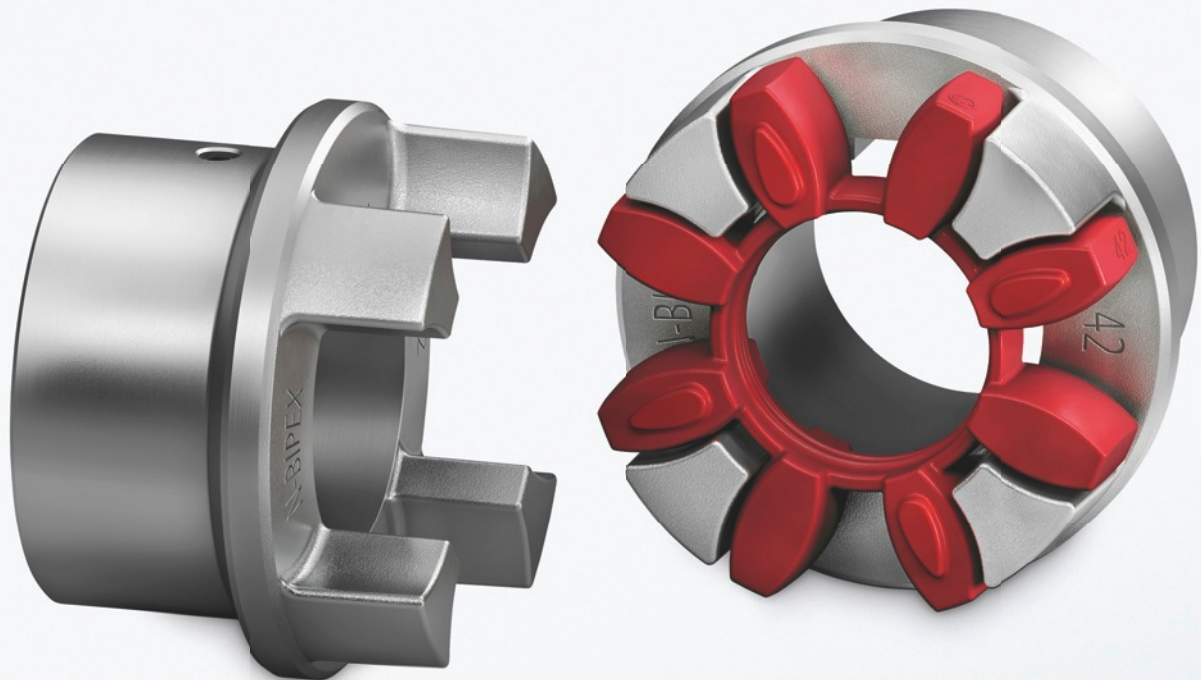

FLENDER Standard Couplings



















N-BIPEX

FLENDER couplings

Catalog
MD 10.1 N

Edition
October
2016

Related catalogs

<p>ARPEX High Performance Couplings</p> <p>MD 10.2</p> <p>E86060-K5710-A121-A1-7600</p>		<p>Bucket Elevator Drives</p> <p>MD 20.2</p> <p>E86060-K5720-A121-A3-6300</p>	
<p>SIPEX and BIPEX-S Backlash-free Couplings</p> <p>MD 10.3</p> <p>E86060-K5710-A131-A1-7600</p>		<p>PLANUREX 2 Planetary Gear Units</p> <p>MD 20.3</p> <p>E86060-K5720-A131-A2-6300</p>	
<p>ARPEX Composite Couplings</p> <p>MD 10.5</p> <p>E86060-K5710-A151-A2-7400</p>		<p>Paper Machine Drives</p> <p>MD 20.5</p> <p>E86060-K5720-A151-A2-6300</p>	
<p>ARPEX Couplings Miniature</p> <p>MD 10.10</p> <p>E86060-K5710-A211-A2-6300</p>		<p>Conveyor Drives</p> <p>MD 20.6</p> <p>E86060-K5720-A161-A2-6300</p>	
<p>ARPEX Torque Limiters</p> <p>MD 10.11</p> <p>E86060-K5710-A221-A2-7400</p>		<p>Marine Reduction Gearboxes</p> <p>MD 20.7</p> <p>E86060-K5720-A171-A1-7400</p>	
<p>FLENDER SIP Standard Industrial Planetary Gear Units</p> <p>MD 31.1</p> <p>E86060-K5731-A111-A5-7600</p>		<p>DUORED 2 Helical Gear Units, Load-sharing</p> <p>MD 20.8</p> <p>E86060-K5720-A181-A1-6300</p>	
<p>Gear Units Sizes 3–22</p> <p>MD 20.1</p> <p>E86060-K5720-A111-A2-6300</p>		<p>Pinion Drive for Tube Mills</p> <p>MD 20.9</p> <p>E86060-K5720-A191-A1-7400</p>	
<p>Gear Units Sizes 23–28</p> <p>MD 20.11</p> <p>E86060-K5720-A211-A3-6300</p>		<p>SIMOGEAR Geared Motors</p> <p>MD 50.1</p> <p>E86060-K5250-A111-A4-7600</p>	
<p>Gear Units Fast Track</p> <p>MD 20.12</p> <p>E86060-K5720-A221-A1-6300</p>		<p>Industry Mall Information and Ordering Platform in the Internet:</p> <p>www.siemens.com/industrymall</p>	

Flexible Couplings N-BIPEX Series

9



9/2	Overview
9/2	Benefits
9/2	Application
9/3	Function
9/3	Design
9/4	Technical specifications
9/6	Type BWN
9/6	Selection and ordering data
9/7	Type BWT
9/7	Selection and ordering data
9/8	Type BNT
9/8	Selection and ordering data
9/9	Spare and wear parts
9/9	Selection and ordering data

FLENDER Standard Couplings

Flexible Couplings – N-BIPEX Series

General

Overview

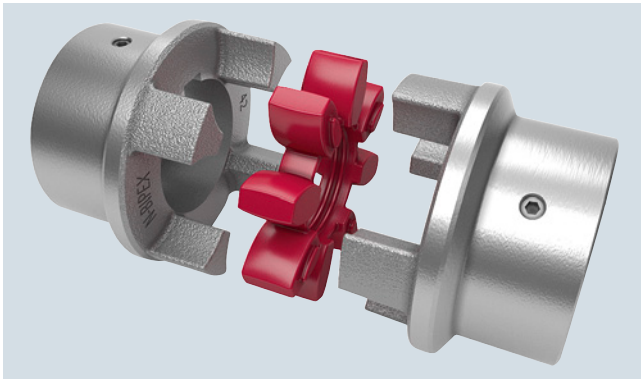

N-BIPEX couplings are torsionally flexible and are outstanding for their particularly compact design and low weight.

N-BIPEX couplings are used in many areas of mechanical engineering.

Their main area of use is in electric motor drives which are well aligned and have uniform torque loads, such as in hydraulic applications and in combinations with geared motors.

Benefits

N-BIPEX couplings are suitable for horizontal, vertical and freely selectable mounting positions. They are able to absorb axial, radial and angular misalignment.

N-BIPEX couplings consist of two identical hub parts which can be arranged as required on the shaft extensions to be connected. N-BIPEX couplings transmit the torque positively and are thus fail-safe. The curved design of the cast cams ensures that the N-BIPEX couplings have a perfect pressure distribution and this increases the elastomer lifetime.

The flexible cam rings responsible for torque transmission and misalignment compensation are available in different Shore hardnesses. As a result of the good damping capability and by selecting the suitable stiffness, torque shock loads can thus be absorbed and the torsional vibration behavior of the drive can be positively influenced. Different cam ring versions and ready-to-install hub parts are available from stock.

Application

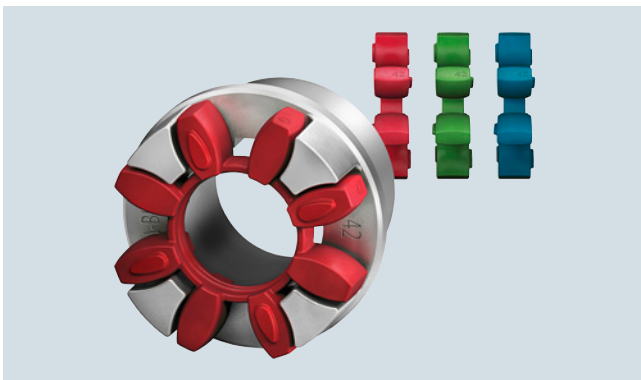

The N-BIPEX coupling is available as a catalog standard in 10 sizes with rated torques of between 12 Nm and 4650 Nm and is made of high-grade spheroidal graphite cast iron.

The extremely high-performance cam ring materials are available from stock in three different Shore hardnesses with the following colors:

- 92 ShoreA – red
- 95 ShoreA – green
- 64 ShoreD – blue





An additional size marking has been provided on the outer surface of the cam ring to be able to determine the size of the N-BIPEX even when it is in the assembled state without having to use any additional aids.

The coupling is suitable for use at ambient temperatures between -50 °C and $+100\text{ °C}$ without any restrictions on the rated torque as a result of temperature factors.

Coupling suitable for use in potentially explosive atmospheres.

Complies with the current ATEX Directive for:

CE  II 2G c IIB TX
 $-50\text{ °C} \leq T_a \leq +100\text{ °C X}$

CE  II 2D c TX
 $-50\text{ °C} \leq T_a \leq +90\text{ °C X}$

CE  I M2 c
 $-50\text{ °C} \leq T_a \leq +100\text{ °C X}$

Function

The torque is transmitted to the hub at the drive end via the shaft-hub connection, which is mostly designed as a keyway connection, and is transmitted to the hub on the output side via the cam ring. This hub then further transmits the torque to the driven machine or a gear unit placed in between. The special cam ring design helps to keep the compression-loaded cam ring ele-

ments in their defined position under all operating conditions and to keep them evenly loaded. This results in a long lifetime of the flexible elements. A long lifetime is also guaranteed by the hub parts which ensure maximum operational reliability even under harsh operating conditions.

Design

The N-BIPEX coupling of type BWN comprises two identical hub parts connected by a cam ring of elastomer material.

The hubs are connected to the respective shafts via finished bores with parallel keyway connection or Taper clamping bushes.

N-BIPEX couplings are positive-locking and torsionally flexible thanks to the thermoplastic polyurethane cam ring.

Coupling materials

Hubs:

EN-GJS-400-15

Cam ring:

- TPU 92 ShoreA -50 °C to +100 °C without any restrictions
- TPU 95 ShoreA -50 °C to +100 °C without any restrictions
- TPU 64 ShoreD -50 °C to +100 °C without any restrictions

Types of N-BIPEX coupling

Type	Description
BWN	Coupling as a shaft-to-shaft connection with drilled and grooved hubs
BWT	Coupling as a shaft-shaft connection with Taper clamping bushes
BNT	Coupling as a shaft-shaft connection with drilled and grooved hubs and a Taper clamping bush

The coupling comprises the following:

- Cam ring
- 2 hub parts with identical cams. The hub parts are designed with a bore and keyway to DIN 6885-1 or with a taper bore for mounting a Taper clamping bush.

Fitting the clamping bush connects the hub firmly to the machine shaft.

In the case of part 4 the Taper clamping bush is inserted from the machine housing side. If there is insufficient space, the Taper clamping bush cannot be fitted from this side. Besides space for fitting the Taper clamping bush, space for the fitting tool (offset screwdriver) must be taken into consideration. In the case of part 3 the Taper clamping bush is inserted from the shaft end face side. The hub must be fitted before the machines to be connected are pushed together.

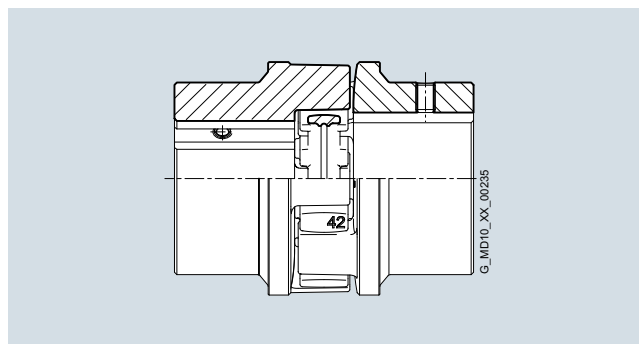

Type BWN

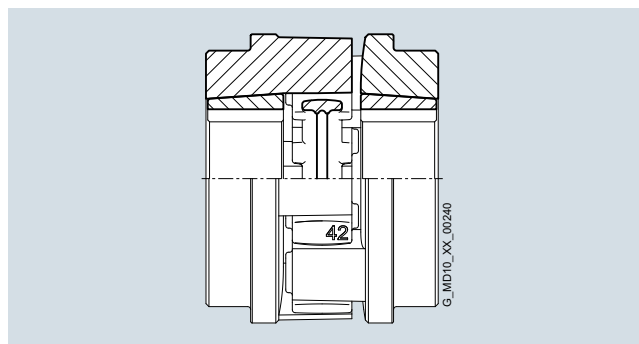

Type BWT

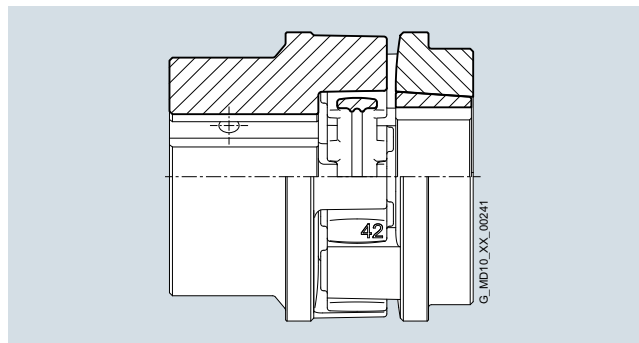

Type BNT

Size	Un-drilled	Preferred bores part 1/2 from stock with cylindrical finished bores \varnothing in mm H7, parallel keyway according to DIN 6885-1 JS9																																							
		10	11	12	14	15	16	17	18	19	20	22	24	25	28	30	32	35	38	40	42	45	48	50	55	60	65	70	75	80	85	90	100	110	120						
19																																									
24																																									
28																																									
38																																									
42																																									
48																																									
55																																									
65																																									
75																																									
90																																									

Preferred bores

FLENDER Standard Couplings

Flexible Couplings – N-BIPEX Series

General

Technical specifications

Cam rings

Cam rings of polyurethane 92 ShoreA (standard)

Size	Rated torque	Maximum torque	Fatigue torque	Maximum speed $V \leq 45 \text{ m/s}$	Damping coefficient Ψ	Torsional stiffness at 50 % capacity utilization	Permitted shaft misalignment at ¹⁾		
	T_{KN} Nm	T_{Kmax} Nm	T_{KW} Nm	n_{max} rpm		$C_{Tdyn} 50 \%$ Nm/rad	< 10 Hz ΔK_a mm	n = 1500 rpm ΔK_r mm	ΔK_w degrees
19	12	36	2	19500	1.4	530	0.30	0.17	0.5
24	45	135	7	14500	1.4	1790	0.40	0.23	0.5
28	95	285	14	12500	1.4	3060	0.50	0.25	0.5
38	190	570	29	10000	1.4	6500	0.60	0.29	0.5
42	265	795	40	8500	1.4	8200	0.70	0.34	0.5
48	330	990	50	7500	1.4	10000	0.80	0.38	0.5
55	460	1380	70	6500	1.4	14500	0.90	0.40	0.5
65	670	2010	100	6000	1.4	25600	1.00	0.45	0.5
75	1400	4200	210	5000	1.4	37400	1.20	0.52	0.5
90	2500	7500	375	4000	1.4	62700	1.40	0.60	0.5

Cam rings of polyurethane 95 ShoreA (ordering option **-Z** and order code **K01**)

Size	Rated torque	Maximum torque	Fatigue torque	Maximum speed $V \leq 45 \text{ m/s}$	Damping coefficient Ψ	Torsional stiffness at 50 % capacity utilization	Permitted shaft misalignment at ¹⁾		
	T_{KN} Nm	T_{Kmax} Nm	T_{KW} Nm	n_{max} rpm		$C_{Tdyn} 50 \%$ Nm/rad	< 10 Hz ΔK_a mm	n = 1500 rpm ΔK_r mm	ΔK_w degrees
19	18	54	3	19500	1.4	1130	0.27	0.15	0.4
24	65	195	10	14500	1.4	4240	0.36	0.21	0.4
28	160	480	25	12500	1.4	8050	0.45	0.23	0.4
38	325	975	50	10000	1.4	14100	0.54	0.26	0.4
42	450	1350	70	8500	1.4	16200	0.63	0.31	0.4
48	550	1650	85	7500	1.4	23300	0.72	0.34	0.4
55	700	2100	105	6500	1.4	28500	0.81	0.36	0.4
65	1000	3000	150	6000	1.4	35000	0.90	0.41	0.4
75	2000	6000	300	5000	1.4	66300	1.08	0.47	0.4
90	3700	11100	555	4000	1.4	105000	1.26	0.54	0.4

Cam rings of polyurethane 64 ShoreD (ordering option **-Z** and order code **K04**)

Size	Rated torque	Maximum torque	Fatigue torque	Maximum speed $V \leq 45 \text{ m/s}$	Damping coefficient Ψ	Torsional stiffness at 50 % capacity utilization	Permitted shaft misalignment at ¹⁾		
	T_{KN} Nm	T_{Kmax} Nm	T_{KW} Nm	n_{max} rpm		$C_{Tdyn} 50 \%$ Nm/rad	< 10 Hz ΔK_a mm	n = 1500 rpm ΔK_r mm	ΔK_w degrees
19	25	75	5	19500	1.4	2010	0.24	0.14	0.3
24	90	270	15	14500	1.4	7680	0.32	0.18	0.3
28	200	600	30	12500	1.4	12200	0.40	0.20	0.3
38	405	1215	60	10000	1.4	25100	0.48	0.23	0.3
42	560	1680	84	8500	1.4	32000	0.56	0.27	0.3
48	700	2100	105	7500	1.4	41200	0.64	0.30	0.3
55	925	2775	140	6500	1.4	52600	0.72	0.32	0.3
65	1200	3600	180	6000	1.4	86700	0.80	0.36	0.3
75	2600	7800	390	5000	1.4	143000	0.96	0.42	0.3
90	4650	13950	700	4000	1.4	234000	1.12	0.48	0.3

Torsional stiffness and damping

The values stated in the above table apply to a capacity utilization of 50 %, an excitation amplitude of 10 % T_{KN} with frequency 10 Hz and an ambient temperature of 20 °C. The dynamic torsional stiffness (C_{Tdyn}) is load-dependent and increases in proportion to capacity utilization. The following table shows the correction factors for different nominal load.

$$C_{Tdyn} = C_{Tdyn} 50 \% \cdot FKC$$

Correction factor FKC	Capacity utilization T_N / T_{KN}						
	20 %	40 %	50 %	60 %	70 %	80 %	100 %
92/95 ShoreA and 64 ShoreD	0.56	0.85	1.00	1.17	1.35	1.53	1.92

Furthermore, torsional stiffness and damping depend on the ambient temperature, the frequency and the amplitude of the torsional vibration excitation. More precise torsional stiffness and damping parameters on request.

With flexible couplings the manufacturing process of the rubber elements and their aging primarily influence the stiffness value C_{Tdyn} . For this reason calculation must be made with a tolerance for the dynamic stiffness of $\pm 20 \%$. The specified damping coefficient Ψ is a minimum value with the result that the damping performance of the coupling corresponds at least to the specified value.

¹⁾ The maximum speed must be observed. Please refer to the Operating Instructions for further information on permitted shaft misalignment.

FLENDER Standard Couplings

Flexible Couplings – N-BIPEX Series

General

Permitted shaft misalignment

The permitted shaft misalignment depends on the operating speed. As the speed increases, lower shaft misalignment values are permitted. The following table shows the correction factors for different speeds. The maximum speed depending on the respective coupling size and type must be observed!

$$\Delta K_{\text{perm}} = \Delta K_{1500} \cdot \text{FKV}$$

	Speed in rpm			
	500	1000	1500	3000
Correction factor FKV	1.20	1.10	1.00	0.70

The axial misalignment may occur dynamically at frequencies up to 10 Hz. For fitting, the maximum gap dimension of $S2_{\text{max.}} = S2 + \Delta S2$ and the minimum gap dimension of $S2_{\text{min.}} = S2 - \Delta S2$ are permitted.

The shaft misalignments ΔK_a , ΔK_r and ΔK_w may occur simultaneously (see [Catalog MD 10.1, page 2/2](#)).

Assignment of N-BIPEX sizes to output P_M of IEC standard motors

The assignment applies for a service factor of 1.25 and the use of a standard cam ring (92 ShoreA).

Three-phase motor Size	Motor		N-BIPEX coupling Size	Motor		N-BIPEX coupling Size	Motor		N-BIPEX coupling Size	Motor		N-BIPEX coupling Size	DE shaft end D x E acc. to IEC	
	Output at ≈ 3000 rpm P_M kW T Nm			Output at ≈ 1500 rpm P_M kW T Nm			Output at ≈ 1000 rpm P_M kW T Nm			Output at ≈ 750 rpm P_M kW T Nm			D mm	E mm
80	0.75	2.5	19	0.55	3.7	19	0.37	3.9	19	0.18	2.5	19	19	40
	1.1	3.7		0.75	5.1		0.55	5.8		0.25	3.5		19	40
90S	1.5	5	19	1.1	7.5	19	0.75	8	19	0.37	5.3	19	19	40
	1.5	5		1.1	7.5		0.75	8		0.37	5.3		24	50
90L	2.2	7.4	19	1.5	10	24	1.1	12	24	0.55	7.9	24	19	40
	2.2	7.4		1.5	10		1.1	12		0.55	7.9		24	50
100L	3	9.8	24	2.2	15	24	1.5	15	24	0.75	11	24	28	60
				3	20		1.5	15		1.1	16		28	60
112M	4	13	24	4	27	24	2.2	22	24	1.5	21	24	28	60
132S	5.5	18	28	5.5	36	28	3	30	28	2.2	30	28	38	80
	7.5	25		7.5	49		4	40		3	40		38	80
132M							5.5	55					38	80
							7.5	75					42	110
160M	11	36	38	11	72	38	7.5	75	38	4	54	38	42	110
	15	49		15	98		11	109		7.5	100		5.5	74
160L	18.5	60	38	15	98	38	11	109	38	7.5	100	38	42	110
180M	22	71	38	18.5	121	38							48	110
180L				22	144	38	15	148	42	11	145	42	48	110
200L	30	97	42	30	196	42	18.5	181	42	15	198	42	55	110
	37	120		22	215		22	215		15	198		55	110
225S				37	240	48				18.5	244	48	60	140
225M	45	145	42										55	110
250M				45	292	55	30	293	55	22	290	55	60	140
	55	177	48	55	356	55	37	361	55	30	392	65	65	140
280S				75	484	65	45	438	65	37	483	65	75	140
	75	241	55										65	140
280M				90	581	75	55	535	75	45	587	75	75	140
	90	289	55										65	140
315S				110	707	75	75	727	75	55	712	75	80	170
	110	353	55										65	140
315M				132	849	75	90	873	75	75	971	75	80	170
	132	423	65										65	140
315L	160	513	65										65	140
	200	641	75										65	140
				160	1030	75	110	1070	75	90	1170	90	80	170
				200	1290	90	132	1280	90	110	1420	90	80	170
315							160	1550	90	132	1710	90	85	170
	250	802	75										65	140
	315	1010	90										65	140
				250	1600	90	200	1930	90				85	170
355	355	1140	90										75	140
	400	1280	90										75	140
	500	1600	90										75	140
400	560	1790	90									80	170	

FLENDER Standard Couplings

Flexible Couplings – N-BIPEX Series

Type BWN

Selection and ordering data

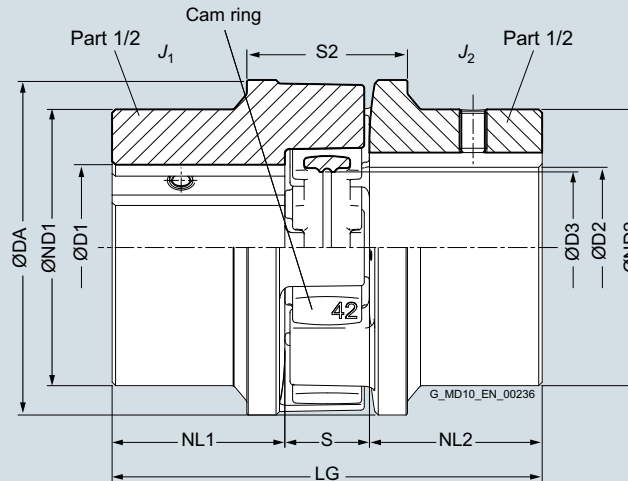

Size	Rated torque			Speed n_{max}	Dimensions in mm										Mass moment of inertia ¹⁾ J_1/J_2	Article No. Order codes for bore diameter and tolerances (see catalog MD 10.1, section 3)	Weight ²⁾ <i>m</i>
	T_{KN}	T_{KN}	T_{KN}		Bore with keyway to DIN 6885-1	DA	ND1/ND2	NL1/NL2	D3	S	S2	ΔS2	LG	kgm ²			
	92 ShoreA	95 ShoreA	64 ShoreD		D1/D2												
	Nm	Nm	Nm	rpm	min ... max												
19	12	18	25	19500	0 ... 25	42	38	25	17	16	31	1.0	66	0.000045	2LC0160-0AA	■ ■ -0AA0	0.3
24	45	65	90	14500	0 ... 35	57	50	30	25	18	37	1.5	78	0.00015	2LC0160-1AA	■ ■ -0AA0	0.6
28	95	160	200	12500	0 ... 40	67	58	35	28	20	41	1.0	90	0.00033	2LC0160-2AA	■ ■ -0AA0	1
38	190	325	405	10000	0 ... 48	82	68	45	36	24	45	1.5	114	0.0009	2LC0160-3AA	■ ■ -0AA0	1.7
42	265	450	560	8500	0 ... 55	97	80	50	43	26	48	1.5	126	0.0019	2LC0160-4AA	■ ■ -0AA0	2.6
48	330	550	700	7500	0 ... 62	107	90	56	48	28	50	2.0	140	0.0031	2LC0160-5AA	■ ■ -0AA0	3.6
55	460	700	925	6500	0 ... 75	123	105	65	57	30	60	2.0	160	0.006	2LC0160-6AA	■ ■ -0AA0	5.2
65	670	1000	1200	6000	0 ... 82	138	115	75	64	35	65	2.5	185	0.011	2LC0160-7AA	■ ■ -0AA0	7.5
75	1400	2000	2600	5000	0 ... 96	163	135	85	76	40	75	2.5	210	0.023	2LC0160-8AA	■ ■ -0AA0	11.5
90	2500	3700	4650	4000	0 ... 120	203	170	100	95	45	85	3.0	245	0.065	2LC0161-0AA	■ ■ -0AA0	21.4

ØD1: • Without finished bore – Without order codes for diameter and tolerance

• With finished bore – With order codes for diameter and tolerance (Article No. without "-Z")

ØD2: • Without finished bore – Without order codes for diameter and tolerance

• With finished bore – With order codes for diameter and tolerance (Article No. without "-Z")

Cam ring

- 92 ShoreA (red)
- 95 ShoreA (green)
- 64 ShoreD (blue)

-Z K01
-Z K04

Ordering example:

N-BIPEX coupling BWN, size 42,

Part 1/2: Bore D1 42 H7 mm, with keyway to DIN 6885-1 and set screw,

Part 1/2: Bore D2 32 H7 mm, with keyway to DIN 6885-1 and set screw.

Article No.:

2LC0160-4AA99-0AA0

LOX+M0T

The Article No. applies to standard cam rings of 92 ShoreA.

¹⁾ Mass moments of inertia apply to a coupling half with maximum bore diameter.

²⁾ Weights apply to the entire coupling in version with maximum bore.

FLENDER Standard Couplings

Flexible Couplings – N-BIPEX Series

Type BWT

Selection and ordering data

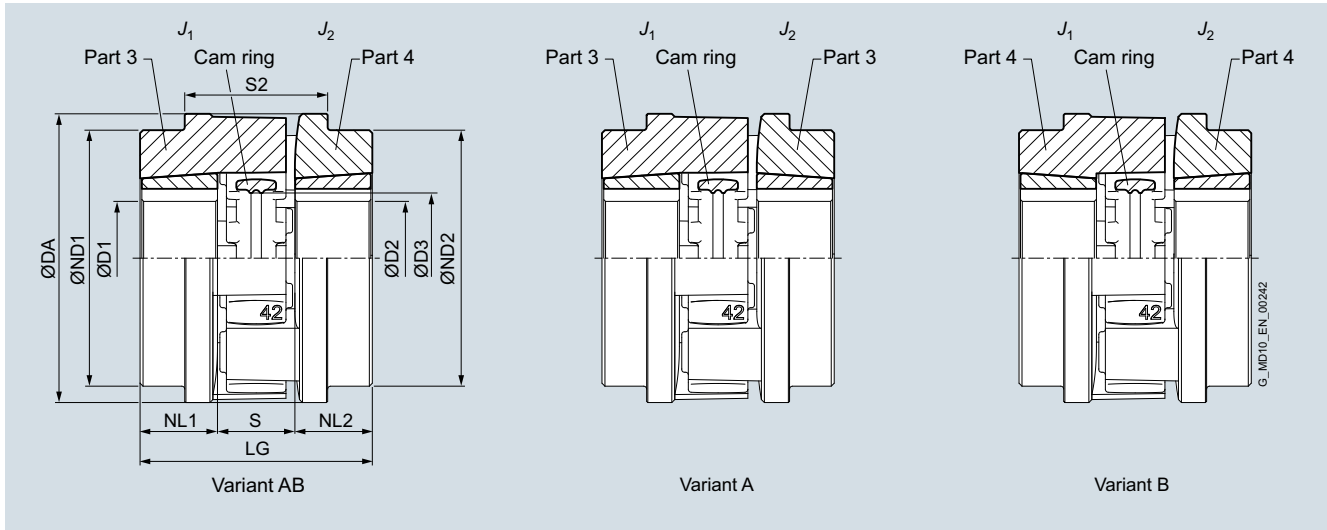

Size	Taper clamping bush 5)	Rated torque T_{KN}	Rated torque 4)	Speed n_{max}	Dimensions in mm	Mass moment of inertia 1)	Article No. Order codes for bore diameter and tolerances (see catalog MD 10.1, section 3)	Weight 2)		
Size	92 ShoreA	95 ShoreA			Bore with keyway to DIN 6885-1	J_1/J_2		m		
	Nm	Nm		rpm	D1/D2 min ... max	kgm ²		kg		
24	1008	45	65	14500	10 ... 25	0.00015	2LC0160-1A	0.6		
28	1108	95	160	12500	10 ... 28	0.00025	2LC0160-2A	0.8		
38	1108	190	325	10000	10 ... 28	0.00050	2LC0160-3A	1.2		
42	1610	265	450	8500	14 ... 42	0.0013	2LC0160-4A	1.8		
48	1615	330	550	7500	14 ... 42	0.002	2LC0160-5A	2.6		
55	2012	460	700	6500	14 ... 50	0.004	2LC0160-6A	3.5		
65	2012	670	1000	6000	14 ... 50	0.006	2LC0160-7A	4.5		
	55 ... 60				118 46				127 0.008	
75	2517	1400	2000	5000	16 ... 60	0.015	2LC0160-8A	7.7		
	3020				163 118 46				132 0.015	
90	3020	2500	3700	4000	25 ... 75	0.017	2LC0161-0A	12.9		
	3535				142 52				144 0.017	
Variant:		• A						B		
		• B							C	
		• AB							D	
ØD1:	• Without Taper clamping bush – Without order codes for diameter and tolerance							1		
	• With Taper clamping bush – With order codes for diameter and tolerance (Article No. without "-Z")								9	
ØD2:	• Without Taper clamping bush – Without order codes for diameter and tolerance							1		
	• With Taper clamping bush – With order codes for diameter and tolerance (Article No. without "-Z")								9	
Cam ring	• 92 ShoreA (red)							-Z K01		
	• 95 ShoreA (green)									
	• 64 ShoreD (blue)								-Z K04	

Ordering example:

N-BIPEX coupling BWT, size 42, variant AB
 Part 3: Taper clamping bush, size 1610,
 bore D1 38 H7 mm, with keyway to DIN 6885-1,
 Part 4: Taper clamping bush, size 1610,
 bore D2 32 H7 mm, with keyway to DIN 6885-1

Article No.:
2LC0160-4AD99-0AA0
LOV+M0T

Article No. applies to standard cam rings with 92 ShoreA.

1) Mass moments of inertia apply to a coupling half without Taper clamping bushes.

2) Weights apply to the entire coupling in version without Taper clamping bushes.

3) Version Taper clamping bushes only available in part 4.

4) T_{Kmax} of cam ring 95 ShoreA is limited to $2 \times T_{KN}$ for types BWT and BNT, contrary to table on page 9/4.
 If cam ring 64 ShoreD is used, the same torque values apply as for cam ring 95 ShoreA.

5) Bores partly with shallow keyway, see catalog MD 10.1, section 14.

FLENDER Standard Couplings

Flexible Couplings – N-BIPEX Series

Type BNT

Selection and ordering data

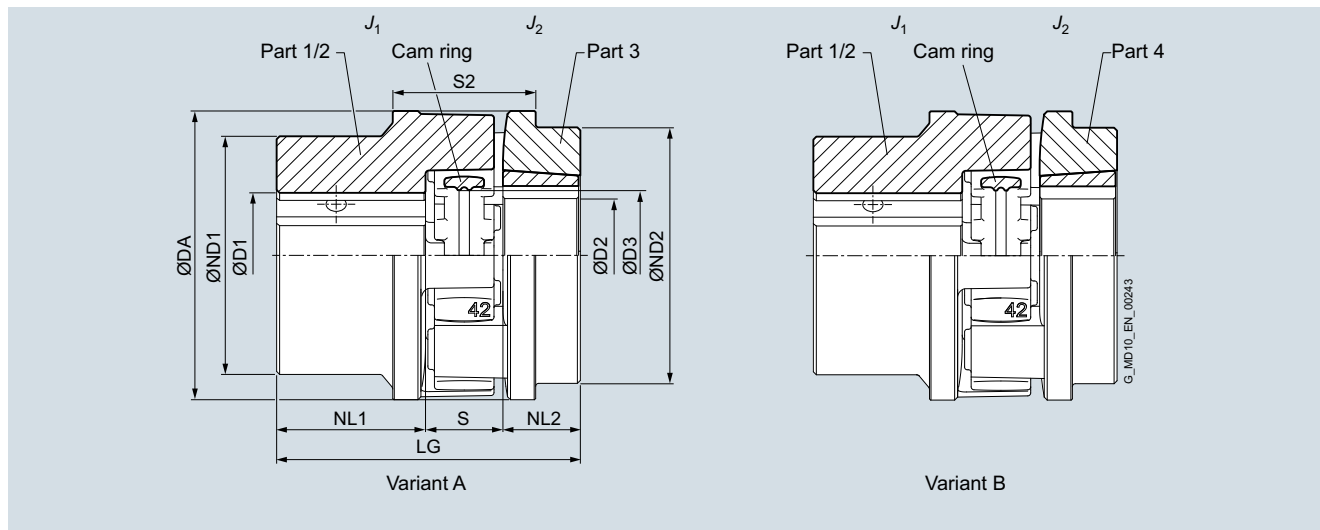

Size	Taper clamping bush ⁵⁾	Rated torque ⁴⁾ T_{KN}	Rated torque ⁴⁾ T_{KN}	Speed n_{max}	Dimensions in mm															Mass moment of inertia ¹⁾	Article No. Order codes for bore diameter and tolerances (see catalog MD 10.1, section 3)	Weight ²⁾
Size	92 ShoreA	95 ShoreA		Bore with keyway to DIN 6885-1	D1	D2	DA	ND1	ND2	NL1	NL2	D3	S	S2	AS2	LG	J_1	J_2		m		
	Nm	Nm	rpm	min ... max													kgm ²	kgm ²		kg		
24	1008	45	65	14500	0 ... 35	10 ... 25	57	50	54	30	23	25	18	37	1.5	71	0.00015	0.00015	2LC0160-1A	0.6		
28	1108	95	160	12500	0 ... 40	10 ... 28	67	58	58	35	23	28	20	41	1.0	78	0.0003	0.0002	2LC0160-2A	0.8		
38	1108	190	325	10000	0 ... 48	10 ... 28	82	68	58	45	23	36	24	45	1.5	92	0.0009	0.0005	2LC0160-3A	1.4		
42	1610	265	450	8500	0 ... 55	14 ... 42	97	80	86	50	26	43	26	48	1.5	102	0.002	0.0013	2LC0160-4A	2.3		
48	1615	330	550	7500	0 ... 62	14 ... 42	107	90	80	56	39	48	28	50	2.0	123	0.003	0.002	2LC0160-5A	3.2		
55	2012	460	700	6500	0 ... 75	14 ... 50	123	105	100	65	33	57	30	60	2.0	128	0.006	0.004	2LC0160-6A	4.4		
65	2012	670	1000	6000	0 ... 82	14 ... 50	138	115	100	75	33	64	35	65	2.5	143	0.011	0.006	2LC0160-7A	6.0		
	2517 ³⁾				55 ... 60			118		46						156	0.011	0.008		6.5		
75	2517	1400	2000	5000	0 ... 96	16 ... 60	163	135	118	85	46	76	40	75	2.5	171	0.023	0.014	2LC0160-8A	9.4		
	3020 ³⁾				65 ... 75			142		52						177	0.023	0.016		9.6		
90	3020	2500	3700	4000	0 ... 120	25 ... 75	205	170	142	100	52	95	45	85	3.0	197	0.065	0.036	2LC0161-0A	17.2		
	3535 ³⁾				80 ... 90			170		90						235	0.065	0.06		20.7		

Variant:	• A	E
	• B	F
ØD1:	• Without finished bore – Without order codes for diameter and tolerance	1
	• With finished bore – With order codes for diameter and tolerance (Article No. without "-Z")	9
ØD2:	• Without Taper clamping bush – Without order codes for diameter and tolerance	1
	• With Taper clamping bush – With order codes for diameter and tolerance (Article No. without "-Z")	9
Cam ring	• 92 ShoreA (red)	
	• 95 ShoreA (green)	
	• 64 ShoreD (blue)	-Z K01
		-Z K04

Ordering example:

N-BIPEX coupling BNT, size 42, variant B
 Part 1/2: Bore D1 42 H7 mm, with keyway to DIN 6885-1 and set screw,
 Part 4: With Taper clamping bushes, size 1610, bore D2 32 H7 mm, with keyway to DIN 6885-1

Article No.:
2LC0160-4AF99-0AA0
LOX+M0T

Article No. applies to standard cam rings with 92 ShoreA.

1) Mass moments of inertia apply to a coupling half with maximum bore diameter and without Taper clamping bushes.
 2) Weights apply to the entire coupling in version without Taper clamping bushes.
 3) Version Taper clamping bushes only available in part 4.

4) T_{Kmax} of cam ring 95 ShoreA is limited to $2 \times T_{KN}$ for types BWT and BNT, contrary to table on page 9/4.
 If cam ring 64 ShoreD is used, the same torque values apply as for cam ring 95 ShoreA.

5) Bores partly with shallow keyway, see catalog MD 10.1, section 14.

FLENDER Standard Couplings

Flexible Couplings – N-BIPEX Series

Spare and wear parts

Selection and ordering data

Size	Article No. N-BIPEX cam ring			Weight kg
	92 ShoreA	95 ShoreA	64 ShoreD	
19	2LC0160-0WA00-0AA0	2LC0160-0WA00-0AA0-Z K01	2LC0160-0WA00-0AA0-Z K04	0.006
24	2LC0160-1WA00-0AA0	2LC0160-1WA00-0AA0-Z K01	2LC0160-1WA00-0AA0-Z K04	0.02
28	2LC0160-2WA00-0AA0	2LC0160-2WA00-0AA0-Z K01	2LC0160-2WA00-0AA0-Z K04	0.03
38	2LC0160-3WA00-0AA0	2LC0160-3WA00-0AA0-Z K01	2LC0160-3WA00-0AA0-Z K04	0.04
42	2LC0160-4WA00-0AA0	2LC0160-4WA00-0AA0-Z K01	2LC0160-4WA00-0AA0-Z K04	0.07
48	2LC0160-5WA00-0AA0	2LC0160-5WA00-0AA0-Z K01	2LC0160-5WA00-0AA0-Z K04	0.09
55	2LC0160-6WA00-0AA0	2LC0160-6WA00-0AA0-Z K01	2LC0160-6WA00-0AA0-Z K04	0.1
65	2LC0160-7WA00-0AA0	2LC0160-7WA00-0AA0-Z K01	2LC0160-7WA00-0AA0-Z K04	0.2
75	2LC0160-8WA00-0AA0	2LC0160-8WA00-0AA0-Z K01	2LC0160-8WA00-0AA0-Z K04	0.4
90	2LC0161-0WA00-0AA0	2LC0161-0WA00-0AA0-Z K01	2LC0161-0WA00-0AA0-Z K04	0.6

The cam rings of the N-BIPEX coupling are wear parts.
The service life depends on the operating conditions.

Siemens AG
Process Industries and Drives
Mechanical Drives
Postfach 13 64
46393 BOCHOLT
GERMANY

Subject to change without prior notice
Article No. E86060-K5710-E111-A2-7600
V.6.MKKATA.MDT.001 / Dispo 18408
KG 1016 7.0 PES 12 En
Printed in Germany
© Siemens AG 2016

The information provided in this catalog contains merely general descriptions or characteristics of performance which in case of actual use do not always apply as described or which may change as a result of further development of the products. An obligation to provide the respective characteristics shall only exist if expressly agreed in the terms of contract. Availability and technical specifications are subject to change without notice.
All product designations may be trademarks or product names of Siemens AG or supplier companies whose use by third parties for their own purposes could violate the rights of the owners.